

Scanning Devices Inc.
March 1, 2011

Quarter-trol System - Motor Connections

The Quarter-trol System can be wired to:

1. Switch externally powered Differential and PIV correction motors.

OR

2. Source 110 VAC motor power from the Quarter-trol supply. With this option, power to motors is switched and fused through components in the Quarter-trol enclosure.

Factory wiring implements option 1 above. Motor connections are shown in the drawing on page 2.

Option 2 can be implemented in the field with the procedure below. See the drawing on page 3.

Differential correction motor:

1. Move the white wire from TB1-6 to TB1-5. This connects motor common to AC white.
2. Add a wire jumper on motor terminal output block from TB1-4 to TB1-6. This connects AC black to the common arms of the Differential forward and reverse relays.

PIV correction motor:

1. Move the white wire from TB1-12 to TB1-11. This connects motor common to AC white.
2. Add a wire jumper on motor terminal output block from TB1-12 to TB1-10. This connects AC black to the common arms of the PIV forward and reverse relays.

QUARTER-TROL MOTOR CONNECTOR

15 POSITION TERMINAL STRIP

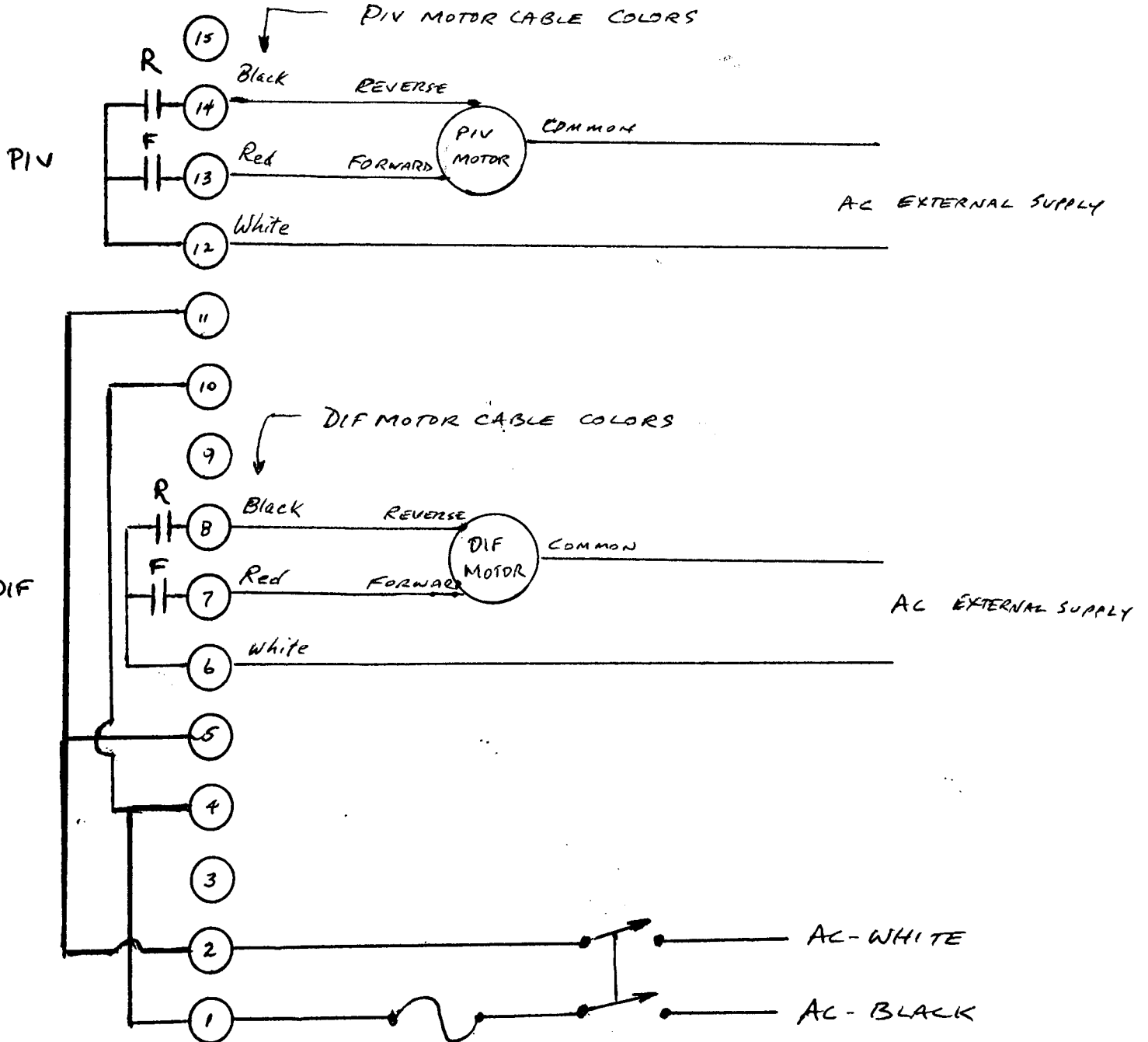

FACTORY WIRED - QUARTER-TROL SWITCHES EXTERNAL POWER

QUARTER-TROL MOTOR CONNECTOR
15 POSITION TERMINAL STRIP

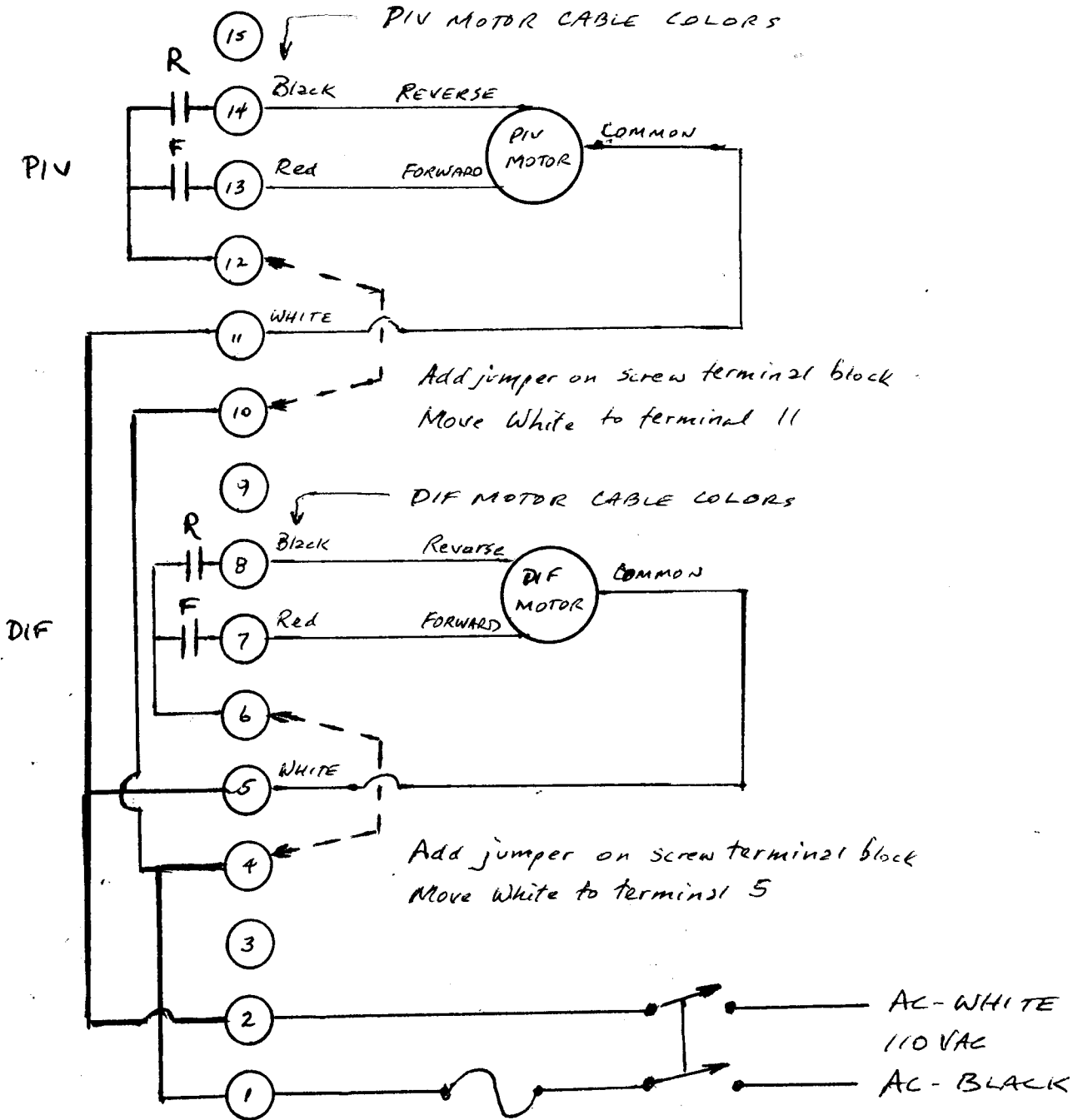

ALTERNATE WIRING - QUARTER-TROL SUPPLIES 110VAC MOTOR POWER
MOTOR POWER IS SWITCHED AND FUSED